

MightyMite Pump - Technical Drawings

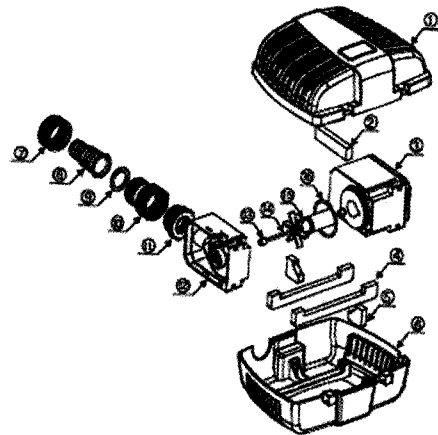

No.	Name	No.	Name	No.	Name	No.	Name
1	Upper Filter Case	5	Rubber Strip 3	9	Gasket	13	Rubber Bearing
2	Rubber Strip 1	6	Lower Filter Case	10	Connecting Flange 1	14	Shaft
3	Motor	7	Nut	11	Connecting Flange 2	15	Impeller
4	Rubber Strip 2	8	Outlet	12	Impeller Chamber	16	O-Ring

pondXpert *MightyMite* Pond Pumps

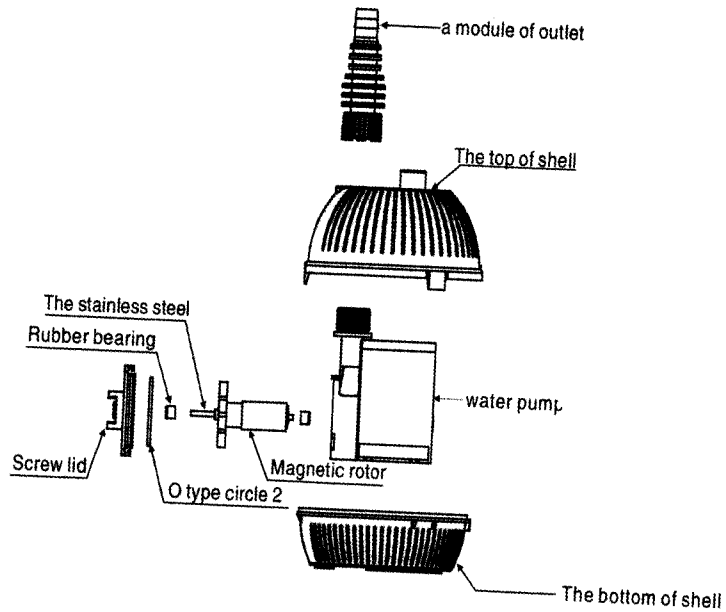

1000 Model

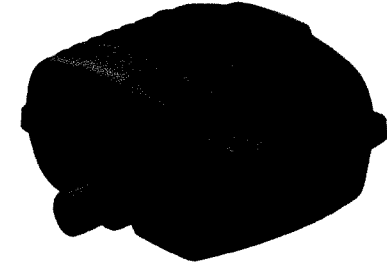

2000-3000 Model

Pond Pump

Model	Power Rating	Max Flow	Max. Head	Dimensions (mm)	Outlet Size	Power Cable
PXMM01000	16W	1000 LPH	1.5m	ø115x88	12-25mm	10m
PXMM02000	35W	2000 LPH	2.0m	203x214x103	20-32mm	10m
PXMM02500	45W	2500 LPH	2.7m	203x214x103	20-32mm	10m
PXMM03000	55W	3000 LPH	3.0m	203x214x103	20-32mm	10m

Rated voltage 220-240V, 50Hz

Introduction

Congratulations on the purchase of your pondXpert pond pump. Used correctly your pond pump will provide years of reliable service

General safety Instructions

Read and observe all of the instructions clearly before installing, connecting and operating the pump.

Make sure the pump is securely and correctly installed before switching on.

Always disconnect the pump when not in use and when carrying out maintenance.

Always disconnect all equipment in the pond before starting to handle, maintain, repair or install any pond equipment.

The appliance is not intended for use by persons (including children) with reduced physical, sensory or mental capabilities, or lack of experience and knowledge, unless they have been given supervision or instruction concerning use of the appliance by a person responsible for their safety.

Children should be supervised to ensure that they do not play with the appliance.

For safety reasons, servicing or repair of this item should only be carried out by pondXpert.

Never hang or carry the pump by the power cord.

Do not operate the pump with a damaged cord or plug. The supply cord of the appliance cannot be replaced.

If the electrical cord is damaged the product should be scrapped.

Safety and Electrical Connections

This unit is designed for outdoor use only. It is waterproof and should be situated safely and securely on a level surface under the pond water. Take care to ensure that you can easily lift your pump out of the water for routine maintenance. If this is necessary do not pick your pump up by the electrical cable but by the main body/ cage of the pump.

The pump is electrically operated so great care must be taken during installation and operation. The following electrical and safety guidelines must be carefully followed.

Each pump is supplied with a 10 metre length of 3 core electrical cable which is permanently connected to the pump.

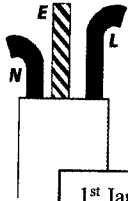

The wires in the mains electrical lead are coloured in accordance with the following code:

- BLUE – Neutral (marked with an “N” in most terminal connections)
- BROWN – LIVE (marked with an “L” in most terminal connections)
- GREEN/YELLOW – EARTH (marked “E” or  in most terminal connections)

1st January 2005 revised Building Regulations for England and Wales installing this product in the garden is classified as ‘notifiable’. The Regulations now require you to tell your local authority building control department that you intend to install this product before installation. Your local authority will let you know how you can get your installation approved

The termination to the mains supply should be permanent, inside a dry weatherproof enclosure, through a double pole switched fused spur with a minimum contact gap of 3mm – (disconnected) to BS 3676 – and fitted with a 3 or 5 amp fuse.

Exposed cable runs should be sensibly positioned, and protected if necessary by armoured conduit.

A 10mA or 30mA Residual Current Circuit Breaker (RCD) MUST be fitted to the mains supply.

Permanent installations to the mains supply (hard wiring) must comply with the regulations of the local electricity authority which may stipulate the use of metal or plastic conduit to protect the cable.

If in any doubt about wiring to the mains supply contact a qualified electrician or your local electricity authority.

Protect from frost. In cold winter the unit may be switched off. It should then be drained of water, removed (if possible) from its installation and stored in a dry, frost-protected area.

Directions for use

Installation

Once installed the pond water will flow through the pump as the pump’s impellor draws in water. Select a suitable location in the pond which provides a solid and level place to place the pump, standing on a block when necessary to avoid sediment / mud. Ensure pump is located a minimum of 12” below water level to avoid air getting into the motor.

Your pump is supplied with a hosetail – attach this part to the pump for connection to pond hose. Pond hose size 25mm (1 inch) can then be attached to the hosetail and secured with a hoseclip (not provided). Other sizes of hose can be attached – the range of sizes available is shown on the first page of this guide.

Maintenance

Keeping your pump clean will improve its function and prolong its life.

Occasionally the pump outer cage will get blocked with debris – where this occurs the cage should be thoroughly cleaned

A clogged or dirty intake will put a strain on the motor and greatly reduce its performance. If the area where the pump is stood is very dirty raising its position slightly will assist flow.

Troubleshooting

The main moving part of the pump is the impellor. If your pump stops working or becomes erratic then the impellor may have got jammed by debris. To check – switch electric off, lift pump out of water and see if the impellor turns freely. Sometimes a turn may be enough to remove grit that has got stuck. Switch back on and try again.

Limited Warranty

This product is guaranteed for a period of 12 months from the date of purchase for material or manufacturing defects. The guarantee covers the substitution of defective parts. However, the guarantee is considered null and void in the case of improper use, improper handling or negligence on the part of the buyer. If your pondXpert pump fails please take it back to the retail outlet from where it was purchased. You will be required to take your receipt/proof of purchase with you. This does not affect your statutory rights.

Pump Flow Curve

The information below illustrates the performance of the pump the higher it needs to pump water. Note that gravity acts as a force against the water reducing flow the higher the water exit point is positioned.

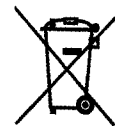
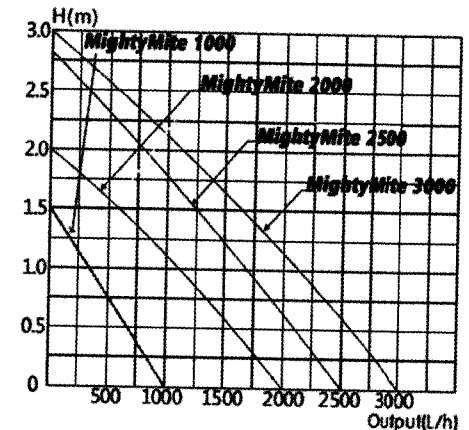

Your appliance contains valuable materials which can be recovered or recycled. Leave it at a local civic waste collection point.

PondXpert
A3 Bentley Avenue
Billingham
TS23 4BU
UK
01642 370888
www.pondxpert.co.uk

9 WARRANTY INFORMATION

This product is guaranteed for a period of 12 months from the date of purchase for material or manufacturing defects. The guarantee covers the substitution of defective parts.. If your pondXpert pump fails please take it back to the retail outlet from where it was purchased. You will be required to take your receipt/proof of purchase with you. This does not affect your statutory rights.

PondXpert,

A3 Bentley Avenue,

Billingham,

TS23 4BU

UK

01642 370898

www.pondxpert.co.uk



Your appliance contains valuable materials which can be recovered or recycled. Leave it at a local civic waste collection point